

# Defender™ Step Ladders



## Key Features

- **Tailored Solutions:** Custom-designed to fit site-specific requirements.
- **Slip Resistant:** Rungs tested in a NATA™-accredited laboratory, ensuring R10 outdoor slip ratings.
- **Durable Components:** Made from non-corrosive aluminium, marine-grade 316 stainless steel, and hot-dipped galvanised steel bolts for enhanced longevity
- **Leak Prevention:** Self-sealing bulb rivets prevent roof leaks.
- **Certified Compliance:** Includes full user documentation, layout details, and compliance labelling to meet AS 1657 safety requirements.
- **Ergonomic Design:** Evenly spaced rungs encourage proper posture and balance during use.
- **Aesthetic Consideration:** Optional powder coating blends the ladder with site aesthetics.

## Specifications

- Ladder installed at a 75-degree incline where possible.
- Brackets installed at minimum 2.4m intervals to maintain a 250kg load rating.
- A minimum 200mm clearance behind step ladders is required.
- Evenly spaced treads, including consistent distance from the bottom tread to landing.
- Treads to be shaped to maximise foothold as proved in ergonomic research
- Labelled for traceability, identification, and system load rating confirmation.
- 10-year warranty, subject to correct installation, use, and maintenance per manufacturer guidelines.

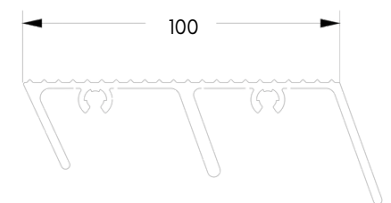
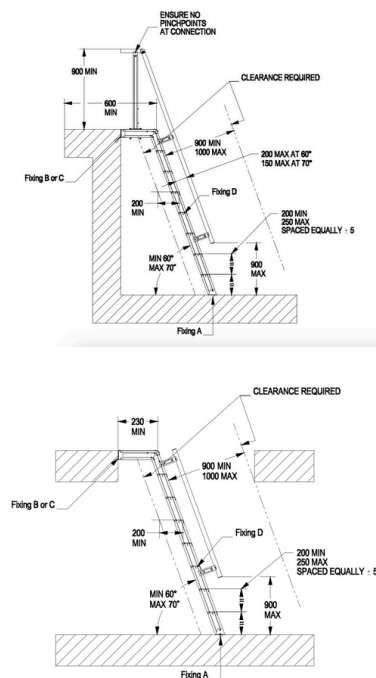
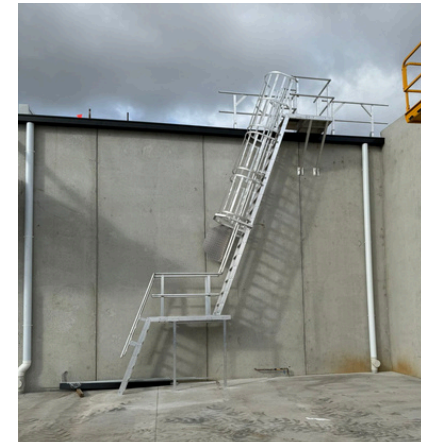

# Our Certifications

At Workplace Defender, we are committed to delivering industry-leading height safety solutions that meet the highest standards of safety, quality, and compliance. Our certifications demonstrate our dedication to providing reliable and regulation-compliant products



## CodeMark Certification

Our certified products meet the National Construction Code (NCC) requirements, ensuring regulatory compliance for architects, builders, and developers.



## ISO 9001 - Quality Management

We maintain a certified quality management system to deliver consistent, high-quality products and services that meet customer and regulatory expectations.



AS/NZS 5532  
SMK40274

## AS/NZS 5532

Our anchor points comply with AS/NZS 5532, the Australian and New Zealand standard for the manufacturing, testing, and performance of height safety anchors.



## ISO 45001 Occupational Health & Safety

Our solutions align with global best practices in workplace safety, ensuring compliance with occupational health and safety management standards.



AS 1657  
SMK40193

## AS1657

Compliance with Australian Standard AS 1657 ensures our platforms, walkways, stairways, and ladders meet strict safety and design requirements.



## ISO 14001 - Environmental Management

We are committed to minimising environmental impact through an internationally recognised environmental management system.



## NATA Accreditation

We uphold rigorous testing and inspection standards under NATA accreditation, ensuring the safety and reliability of our height safety systems.



With these certifications, Workplace Defender ensures compliance, durability, and safety across all our solutions, helping businesses create safer working environments with confidence.

## WHY CHOOSE DEFENDER?

- Independently tested in a NATA™-accredited facility.
- Australian-made, built to withstand harsh environments.
- Cost-effective without compromising on safety or durability.
- Seamless integration with safety systems, including guardrails, platforms, and access hatches.

## CONTACT US

For reliable height safety solutions, call [1300 013 794](tel:1300013794) or visit [www.workplacedefender.com.au](http://www.workplacedefender.com.au)

